

COMPAK

COMPAK

**COMPONENTI E ACCESSORI
PER MACCHINARI INDUSTRIALI**

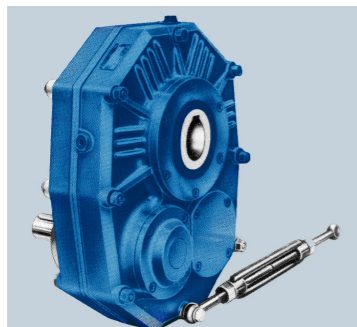
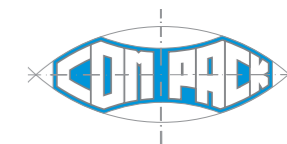
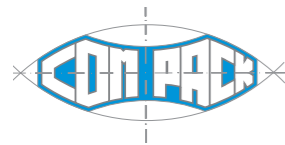

RIDUTTORI PENDOLARI



RINVII AD ANGOLO



RIDUTTORI EPICICLOIDALI



MOTORIDUTTORI HYCLEAN

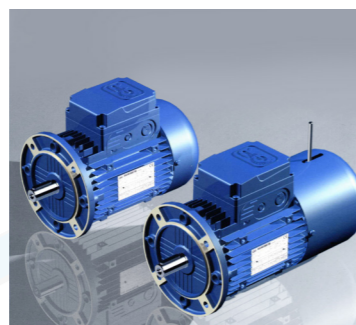

MOTORI TRIFASE NORMALI ED AUTOFRENANTI



SERVOMOTORIDUTTORI SINCRONI E ASINCRONI

MOTORIDUTTORI PER AMBIENTI CORROSIVI ED ASETTICI

ottima igiene/sanificazione e resistenza agli ambienti umidi e corrosivi, soggetti a frequenti lavaggi, in tutte le aree di produzione.

La gamma Rossi Motoriduttori si completa con **RIDUTTORI E MOTORIDUTTORI AD INGRANAGGI** (coassiali, assi paralleli ed ortogonali) E **A VITE SENZA FINE** CON POTENZE DA 0,09 KW A 3650 KW. **RIDUTTORI E MOTORIDUTTORI PER ESTRUSORI ED AGITATORI** **MOTORI CON INVERTER E MOTORI CON INVERTER INTEGRATO.**

STANDARDFIT LA QUALITA' AD UN PREZZO COMPETITIVO

NUOVA GAMMA DI MOTORIDUTTORI ROSSI **A VITE SENZA FINE E COASSIALI**

CARCASSE MONOLITICHE DI GHISA CON FLANGE INTEGRALI

INTERCAMBIABILITA' CON LO STANDARD DI MERCATO

RAPPORTO **PRESTAZIONI/PREZZO** TRA I PIU' COMPETITIVI CON INTATTE LE CARATTERISTICHE DI **ELEVATA QUALITA' E PRECISIONE** TIPICHE DI UN PRODOTTO **ROSSI MOTORIDUTTORI**



DISTRIBUTORE PER LA CAMPANIA



MOTORI PIATTI ESTRUSI AD INGOMBRO RIDOTTO

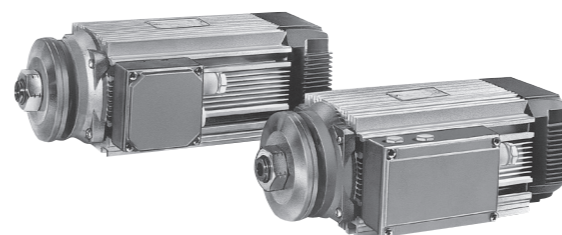

MANDRINO PORTAPINZE

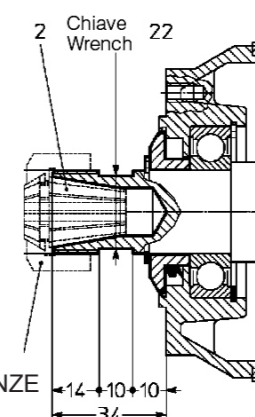

ACCESSORI PER MOTORI PIATTI

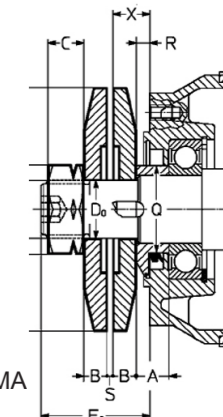

MINI MOTORIDUTTORI EPICICLOIDALI A C.C.

CON FRENO E DINAMO TACHIMETRICA
DIAMETRO RIDUTTORE A PARTIRE DA 34mm
LUNGHEZZA MOTORE A PARTIRE DA 75mm
GIRI IN USCITA DA 0 A 5000 r.p.m.
COPPIE NOMINALI DA 0,025 A 22,5 Nm

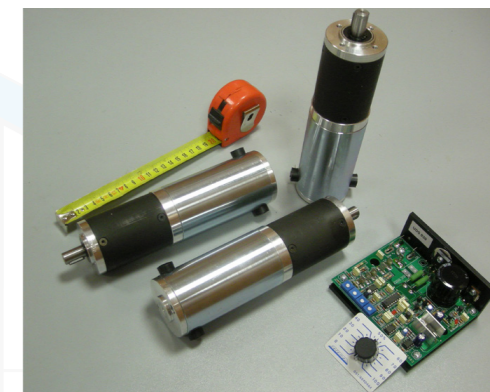

COMPONENTI PNEUMATICI



CILINDRI PNEUMATICI, MINICILINDRI E CILINDRI COMPATTI
CILINDRI PNEUMATICI A CONTROLLO IDRAULICO,
CILINDRI ROTANTI ANCHE CON CONTRLLO IDRAULICO
VALVOLE AD AZIONAMENTO PNEUMATICO, ELETTRICO, MECCANICO E MANUALE,
GRUPPI TRATTAMENTO ARIA,
MANOMETRI E TERMOMETRI





COMPONENTI PER NASTRI TRASPORTATORI



RUOTE DI TRAIANO E DI RINVIO
CATENE A CERNIERA IN ACCIAIO E IN PLASTICA
TAPPETI MODULARI IN PLASTICA



COMPONENTI IN ACCIAIO INOX
BASI DI SOSTEGNO E PIEDINI REGOLABILI



PROFILI E CURVE GUIDACATENE
TESTATE DI APPOGGIO E SUPPORTI

ELEMENTI STRUTTURALI IN ALLUMINIO

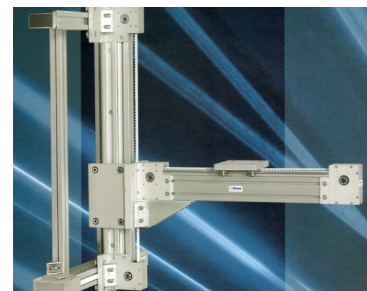

SISTEMI LINEARI
SISTEMI LINEARI MOTORIZZABILI
SLITTE LINEARI

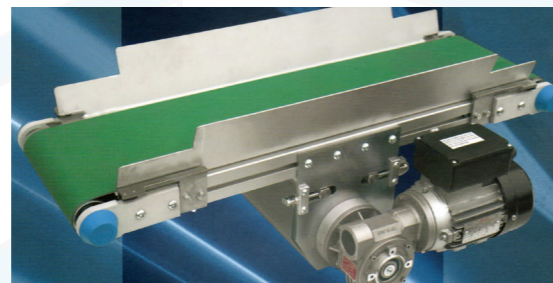

MOTORIZZAZIONE DIRETTA, RINVIATA O INTERMEDIA
TRASPORTATORI A NASTRO O A RULLI

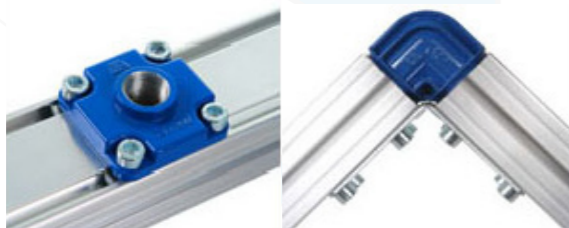

SISTEMI DI DISTRIBUZIONE ARIA ED ALTRI FLUIDI

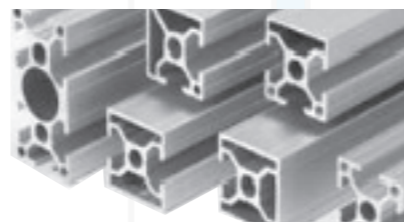

PROFILI ED ACCESSORI

PROTEZIONI ANTINFORTUNISTICHE PER MACCHINE INDUSTRIALI



REALIZZATE SU INDICAZIONE DEL CLIENTE
FORNITURE DI KIT COMPLETI O DI COMPONENTI
POSSIBILITA' DI AVERE PROFILATI ED ALTRI
COMPONENTI IN ACCIAIO INOX

PROTEZIONI PERIMETRALI



VENTOSE ED ARTICOLI TECNICI PER L'INDUSTRIA ALIMENTARE



VENTOSE PER VUOTO CON UNA VASTA SCELTA
DI FORME E MATERIALI PER IMPIEGHI
SETTORE ALIMENTARE, CARTOTECNICO, CHIMICO,
FINO A 200°C

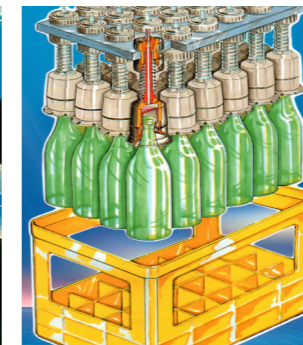

COMPONENTI E RICAMBI
PER MACCHINE
DELL'IMBOTTIGLIAMENTO
ED IL CONFEZIONAMENTO
TUBI GONFIABILI
INCA/DECASSETTATRICI



GUARNIZIONI PER SCAMBIATORI DI
CALORE

SPAZZOLE INDUSTRIALI



SPAZZOLE INDUSTRIALI IN MATERIALI
SINTETICI O NATURALI
STRIP AD AVVOLGIMENTO
STRIP ATTORCIGLIATO
REALIZZAZIONE A DISEGNO O
A CAMPIONE

SOFFIETTI IN GOMMA NATURALE O SINTETICA E PROTEZIONI

SOFFIETTI PIANI E SOFFIETTI CIRCOLARI
PROTEZIONI TELESCOPICHE E
PROTEZIONI A TAPPARELLA
RULLI AVVOLGIBILI

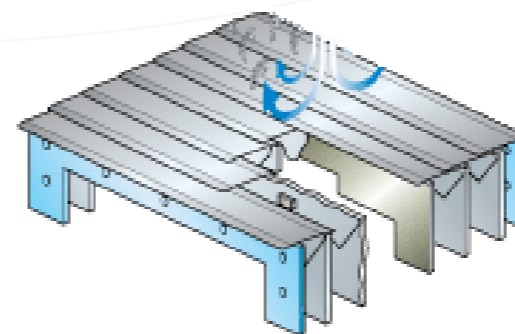

I SOFFIETTI POSSONO ESSERE FORNITI A SECONDA DELLE
ESIGENZE CON COLLARE DI ATTACCO O FLANGIA DI
FISSAGGIO, CON PATTINI DI SCORRIMENTO
(PER VITI O GUIDE) E CON CHIUSURA A VELCRO



TUTTE LE PROTEZIONI IN GOMMA POSSONO
ESSERE REALIZZATE IN QUALUNQUE FORMA
ATTRAVERSO IL METODO AD IMMERSIONE



SEMILAVORATI TERMOPLASTICI

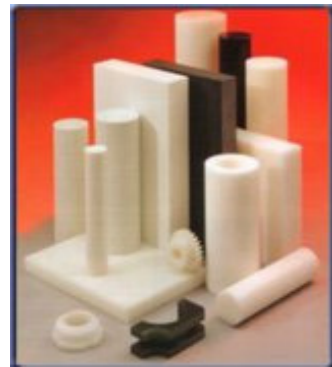

TEFLON, DELRIN, PVC, POLICARBONATO, POM, POLIPROPILENE, POLISTIRENE, POLIETILENE, NYLON, ABS, PEHD, PLEXIGLASS, PEEK, LASTRE EPOSSIDICHE, TELA BACHELIZZATA

BARRE TONDE, PIENE E FORATE
LISTE QUADRE, RETTANGOLARI ED ESAGONALI
LASTRE PIANE PROFILI ESTRUSI

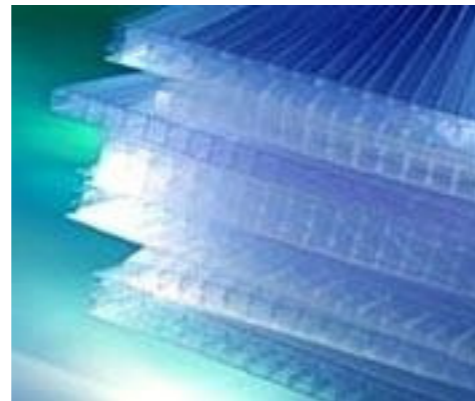

PVC trasparente per porte flessibili

LAVORAZIONE POLIMERI

LAVORAZIONI MECCANICHE DI PARTICOLARI A DISEGNO O A CAMPIONE

ELASTOMERI IN POLIURETANO, VULKOLLAN®, ADIPRENE®

LASTRE IN COLATA E LASTRE CENTRIFUGATE
MANICOTTI, TONDI E BARRE
ARTICOLI TECNICI DA COLATA
RIVESTIMENTO RULLI



PRODOTTI IN POLIETILENE AD ALTA DENSITA'

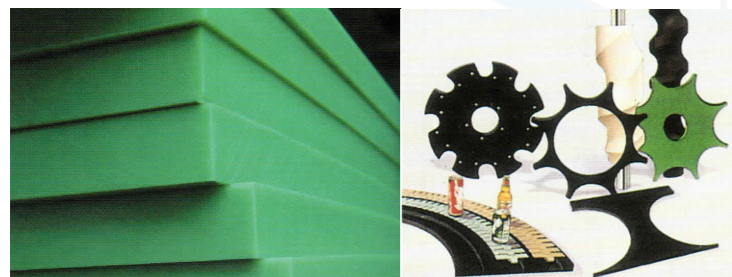

STELLE, COCLEE, CUORI, CURVE E PROFILI
IN POLIETILENE AD ALTA DENSITA'

TUBETTO ARIA COMPRESSA



RILSAN®
PA6, PE,
PU, PVC
TUBI TEFLON

ELASTOMERI TRAFILATI

TUBI, BARRE A SEZIONE
TONDA, QUADRA E RETTANGOLARE,
MANICOTTI E PARABORDI



GOMMA NATURALE E PARA
GOMMA SINTETICA A BASE DI NEOPRENE
EPDM (a base di etilpropilene)
SILICONE, VITON

CANNELLI E GENERATORI DI ARIA CALDA

saldatura, riscaldamento e formatura
termoretrazione, sverniciatura,
indurimento, stagnatura e saldobrasatura
CANNELLI AUTONOMI E ALIMENTATI CON COMPRESSORE
O SOFFIANTE SEPARATA.

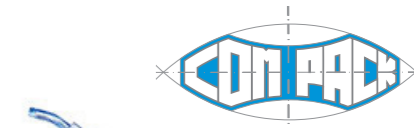

GUARNIZIONI INDUSTRIALI SPECIALI

O-RINGS IN VITON, SILICONE E TEFLON
CORDE O-R IN SILICONE FORNITE IN ROTOLI
ANELLI DI TENUTA
RASCHIATORI GOMMA-METALLO
GUARNIZIONI ENERGIZZATE
GUARNIZIONI PISTONI PER CILINDRI PNEUMATICI



TESSUTO IN VETRO + TEFLON

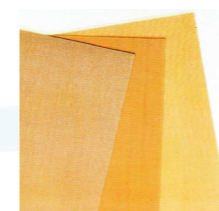

TESSUTO AUTOADESIVO

TESSUTO IN VETRO + SILICONE

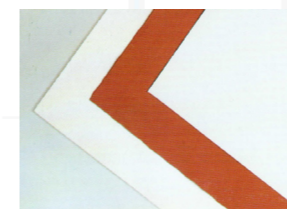

PER TERMORETRAIBILI

RUOTE INDUSTRIALI

FINO A 7000 KG DI PORTATA CON E SENZA FRENO



IN MATERIALE PLASTICO
IN GOMMA
IN GOMMA ELASTICA
IN POLIAMMIDE
IN POLIURETANO
IN GHISA MONOLITICA
IN GOMMA PIENA PER ALTE PORTATE
RUOTE PNEUMATICHE
RULLI PER TRANSPALLET

MOLLE A GAS



ANTIVIBRANTI IN GOMMA E PU PIEDINI ANTIVIBRANTI



RIVESTIMENTO RULLI IN POLIURETANO

RIVESTIMENTO RULLI IN GOMMA

RUOTE PER ARREDAMENTO

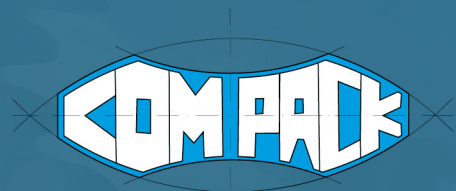

COM.PACK s.a.s.
Polo Meucci, Via A.Meucci, 33
80020 Casavatore (Na)
Tel. 081 7389132 081 7380646
Fax 081 7366058
www.compacksas.it
info@compacksas.it